

ACCESSORIES:

METALLIC HOLDER, ELEMENT SIZES 3/6, 4/9, 6/12, 9/18, and 12/24:

Held in place by a socket head cap screw, this single shank metallic holder is made out of stainless steel.

These metallic holders are quite small in diameter. They will work well in applications where spacing is restricted.

IDENTIFICATION:

Metallic holders are described by the Moly-D element size. As an example, the part description for a 3/6 Moly-D element is 3/6 Metallic Holder.

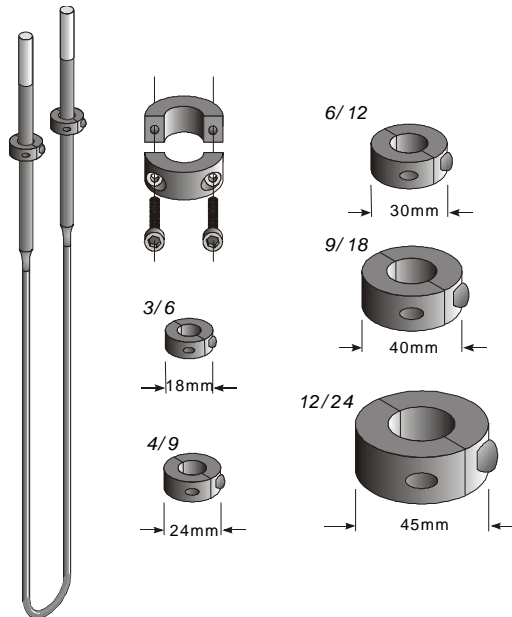

CERAMIC HOLDER, ELEMENT SIZES 6/12, 9/18, and 12/24:

The ceramic holder consists of two ceramic blocks held in place by two pieces of stainless steel angle, hex nuts, and hex head cap screws.

These ceramic holders offer higher temperature capabilities than metallic holders.

IDENTIFICATION:

Ceramic holders are described by the Moly-D element size. As an example, the part description for a 6/12 Moly-D element would be a 6/12 Ceramic Holder.

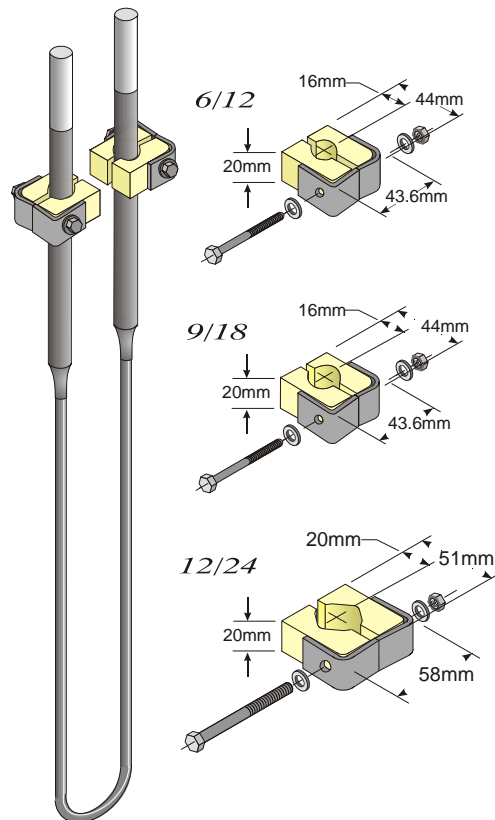

 Moly-D[®]

Molybdenum
Disilicide
Heating Elements



I SQUARED R ELEMENT CO., INC.

PLATE HOLDER

ELEMENT SIZES 3/6, 4/9, and 6/12:

Held in place by a hex nut and slotted head machine screw, the plate holder consists of two ceramic plates, two pieces of ceramic fiber paper and a piece of high-temperature ceramic fiberboard. This fiberboard, referred to as a tab, is located between the ceramic plates. The length of the tab varies depending on the thickness of the furnace roof.

The insulating tab fills the opening from the top of the ceramic plates to the hot face of the furnace chamber. The tab seals and reduces the heat losses between the two element legs.

The main advantage of the plate holder is that the Moly-D elements can be installed from the outside of the furnace.

The plate holder can also be supported without the tab extending below the two plates. The "LL" dimension being zero. In this case, the furnace insulation should have two holes rather than a slot.

IDENTIFICATION:

Plate holders are described by the element size, the "A" dimension, and the tab length. As an example, the part description for a 6/12 Moly-D element with an on center leg spacing (A) of 50mm and furnace roof thickness of 100mm would be a 6/12 Plate Holder, A=50, LL=100.

AVAILABILITY:

All Moly-D holders are in stock and can be shipped within one week after receipt of an order.

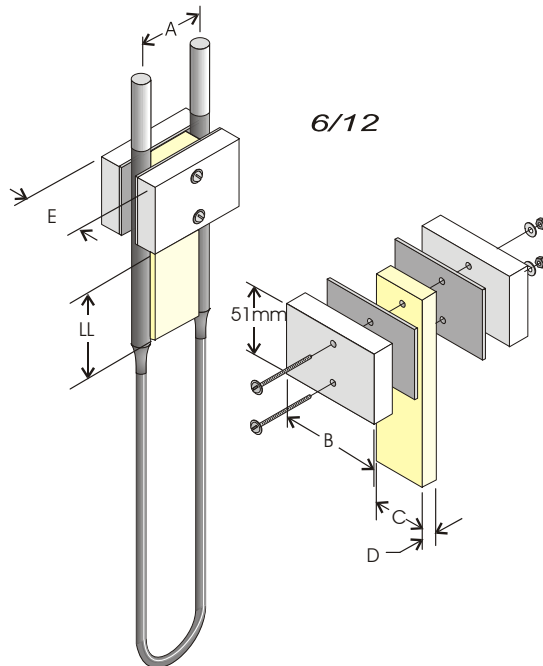
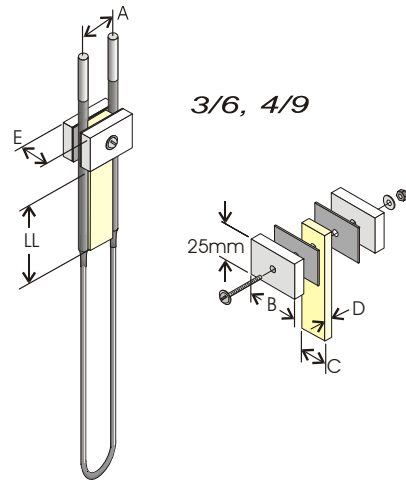

TABLE A - Moly-D Plate Holder

Moly D Diameter	Element Spacing A	Plate Width B	Tab Width C	Tab Thickness D	Overall Thickness E	Tab Length LL
Le/Lu	mm	mm	mm	mm	mm	mm
3/6	20	31.5	14	6	23	50
3/6	25	36.6	19	6	23	50
3/6	40	51.8	34	6	23	50
4/9	20	39.6	11	9	26	75
4/9	25	39.6	16	9	26	75
4/9	40	54.9	31	9	26	75
6/12	40	58.4	28	12	34	100
6/12	50	68.3	38	12	34	100
6/12	55	78.5	43	12	34	100
6/12	60	78.5	48	12	34	100

* The LL (length of the tab) can be longer or shorter. The tabs are made from high-temperature fiber board and are very fragile. A longer tab is more susceptible to breakage.

**COMBINATION CLAMP & STRAP,
ELEMENT SIZES 3/6, 4/9, 6/12, 9/18,
and 12/24:**

The strap assembly is offered in 75, 150, 200, 400 and 600 amperage rating. The binding post to Moly-D (K type strap) is offered for the 4/9, 6/12, 9/18 and 12/24 elements. There are two styles available for the 3/6 element; E-type for connecting binding post to Moly-D, and F-type for connecting Moly-D to Moly-D.

IDENTIFICATION:

Combination straps are described by the element size and working length in centimeters. As an example, the part number for a 75 ampere 3/6 E-2 type strap with a 10 centimeter working length would be an E210.

AVAILABILITY:

E, F, & K straps are available from stock in standard and custom lengths and can be shipped 2-3 days after receipt of an order.

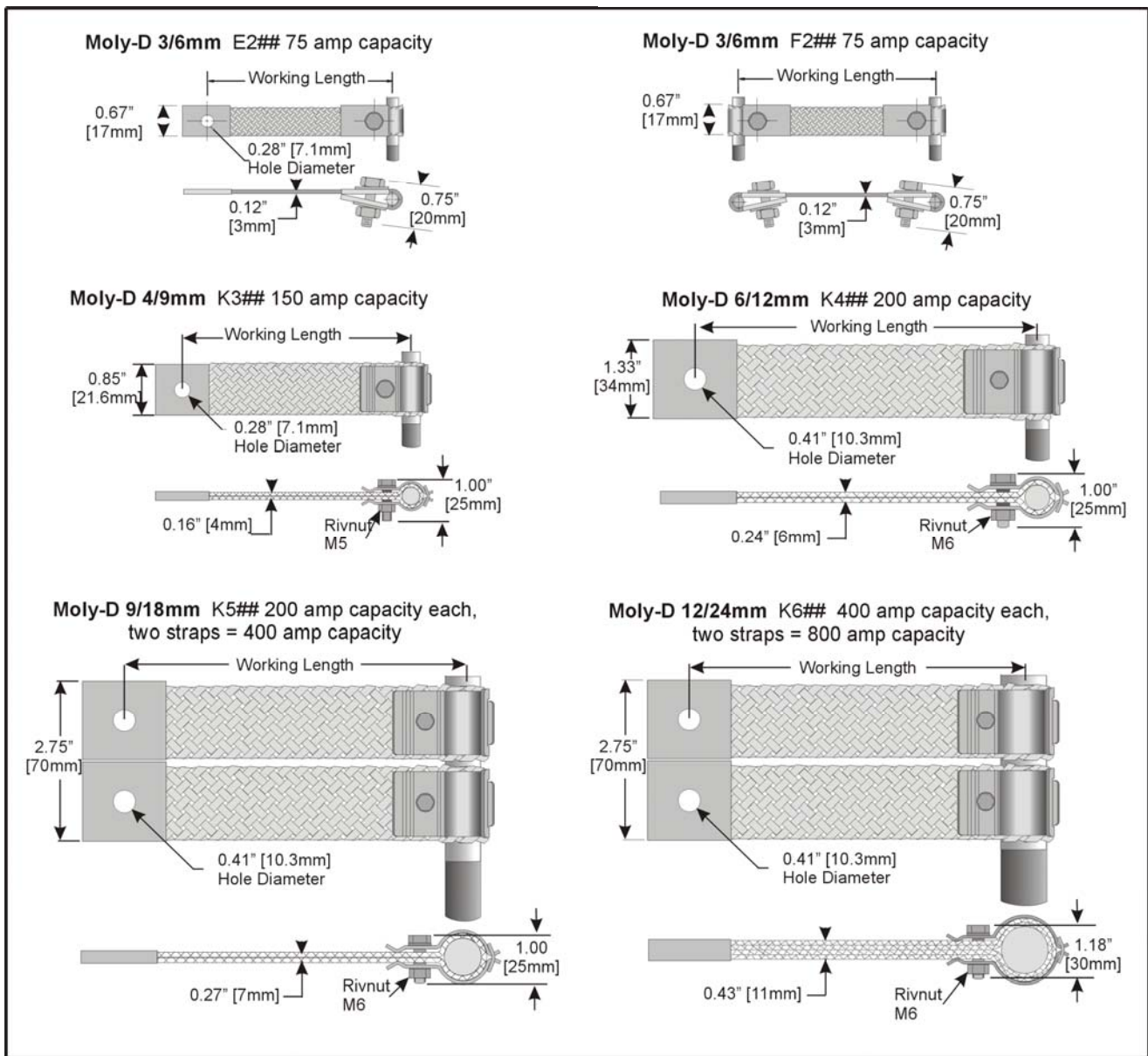

Note: The 9/18 and 12/24 Moly-D straps are sold individually. Order two for each cold end.

INSTALLATION INSTRUCTIONS FOR MOLY-D STRAPS

The combination clamp and strap of the recommended size should always be used. The element terminal ends get hot from the I^2R energy in the cold ends and from the heat conducted from the hot zone out along the cold ends. Using electrical straps of a smaller size or different material can cause the element cold ends and straps to overheat and fail.

Although we offer the F type strap that is used to connect two elements together, we don't recommend their use.

We recommend the E or K type strap be used to connect the element to a post or another E or K type strap.

It is very important that Moly-D straps be initially tightened securely. After the elements are brought to temperature, the nut and bolt should be tightened again. Allow about 24 hours between tightening for the clamp portion of the straps relaxes on the first heating and becomes loose on the element.

If the clamp is loose, it causes a poor electrical connection that is high in resistance which causes the element terminal end to overheat. This can cause the element and terminal strap to fail.

The strap must not cause a bending force, i.e. side force on the element. This will cause the heating section (L_e) to bend and possibly break. We recommend the working length of the strap be approximately 12mm longer than the distance between the two connecting points.

Failure to properly maintain strap-to-element connection will lead to premature failure of element and strap.

If previously used straps are used with new elements they should be examined. Any straps with white powder, broken wire strands, or small globules of aluminum should not be used.

When installing Moly-D elements or straps for the first time:

1. Tighten all strap-to-element connections as follows:

Table C- Torque Range						
Strap Size	Cold End (Lu) Diameter	Inch lbs		Torque Range		
		Min.	Max.	Min.	Max.	Wrench Size
E2 or F2	6mm	24	108	0.277	1.24	7/16 in.
K3	9mm	24	108	0.277	1.24	8mm
K4	12mm	48	108	0.553	1.24	10mm
K5	18mm	48	108	0.553	1.24	10mm
K6	24mm	48	108	0.553	1.24	10mm

* If a torque wrench is not available, connections should be tight enough such that the strap will not move independent of the element.

2. Always tighten with two wrenches. Avoid twisting the element.
3. The nut is stationary on the K type straps. Always use the torque wrench on the bolt.
4. Tighten toward the higher end of the torque range if possible.

For cyclic operation of furnace and elements – Follow the instructions below:

After first heating cycle:

1. Allow elements and straps to cool to near room temperature.
2. Re-tighten all strap-to-element connections using same instructions as shown in table C.
3. Connections should now remain tight for awhile, however, routinely check strap-to-element connections and adjust as needed.

For continuous operation of furnace and elements after installation – Follow the instructions below:

Approximately 48 hours after Moly-D elements have achieved temperature for the first time, or at an appropriate time within the cycle:

1. Turn off power to furnace and elements.
2. Re-tighten all strap-to-element connections using same instructions as above.

Use caution when working with hot elements and straps. Use only approved *I Squared R Element* straps and accessories.

I SQUARED R ELEMENT CO., INC.

PO Box 390, 12600 CLARENCE CENTER ROAD, AKRON, NEW YORK, USA 14001-0390

PHONE (716) 542-5511

FAX (716) 542-2100

Web: www.isquaredrelement.com email: sales@isquaredrelement.com