

TYPE SEU, SILICON CARBIDE HEATING ELEMENTS

GENERAL DESCRIPTION SEU

Made of special high-density reaction-bonded silicon carbide, the SEU Starbar is a tube with both electrical connections on one end. The hot zone is formed by cutting a slot, which reduces the cross sectional area over which the current flows, resulting in higher resistance than the cold end. The cold end is formed by cutting two longitudinal slots along the length of the tube and is made of LRE (low resistance end) material and in most cases is larger in diameter.

The SEU element is supplied with a ceramic collar cemented to the cold end. The cold end of the SEU element is flame sprayed with aluminum for a distance of about two inches. Flat, braided-aluminum straps are held in compression with a stainless steel clamp to this metallized area. The clamp is electrically insulated from the flat braid with high temperature insulation. The aluminum braid is ten inches long and holes are provided for easy connection to the power supply.

Low-Resistance SEU

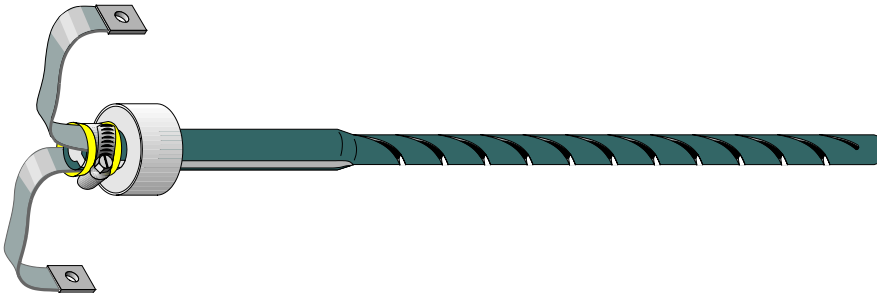

The electrical resistance of the SEU can be customized by varying the spiral width. SEU Starbars can range from high resistance to low resistance. The electrical resistance can be as high as the SER (spiral element with return) and as low as the RR (rammed type) non-spiral Starbar. There are further limits based on the size of the SEU.

High Resistance SEU

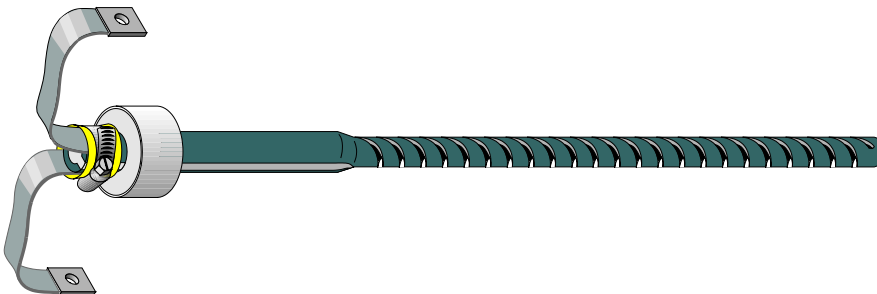

SEU Starbars are described by giving the overall length, the heating section length, and the diameter. As an example, SEU 45 x 30 x 1-1/4 is a SEU Starbar, 45" overall length, 30" hot zone, and 1-1/4" hot zone outer diameter. In metric, SEU 1143 x 762 x 32 is a SEU Starbar, 1143mm overall length, 762mm hot zone and 32mm hot zone outer diameter.



Silicon Carbide
Heating
Elements



I SQUARED R ELEMENT CO., INC.

Recommended Maximum Watt Loading (Figure 1)

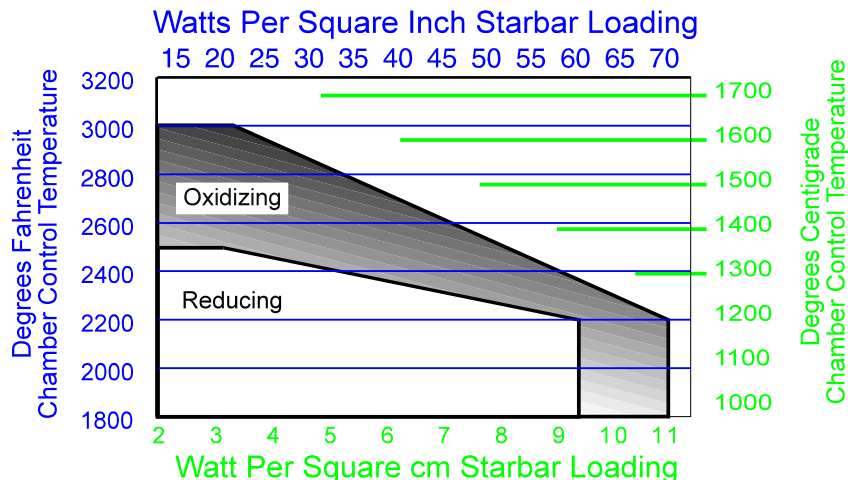

SUPERIOR PERFORMANCE

At 2.7 gms/cc, this high-density low-porosity element is able to survive severe environments. The high density prevents the internal structure from being oxidized. This element therefore has an extremely slow aging characteristic.

OPERATING TEMPERATURES

In an air or inert atmosphere of argon or helium, the SEU Starbars can be operated at furnace temperatures up to 3000°F (1650°C). In reducing atmospheres, the maximum operating temperature is 2500°F (1370°C). See Watt Loading Graph, Figure 1.

There is a protective coating of silicon dioxide on the silicon carbide. Hydrogen reduces this coating and causes the Starbar to deteriorate. Nitrogen atmosphere applications are limited to 2500°F (1370°C) and 20 to 30 watts per square inch (3.1 to 4.6 watts per square centimeter) maximum watt loading. Higher surface temperature will result in silicon nitride formation. A thermally insulating layer forms around the Starbar resulting in very high surface temperatures that damage the Starbars.

SIZES AVAILABLE

SEU Starbars can be manufactured up to 91 inches (2311mm) long. The maximum hot zone length is 62 inches (1575mm) at this printing. Please see Table A, page 3 for diameters and lengths available.

Resistance Temperature Characteristics (Figure 2)

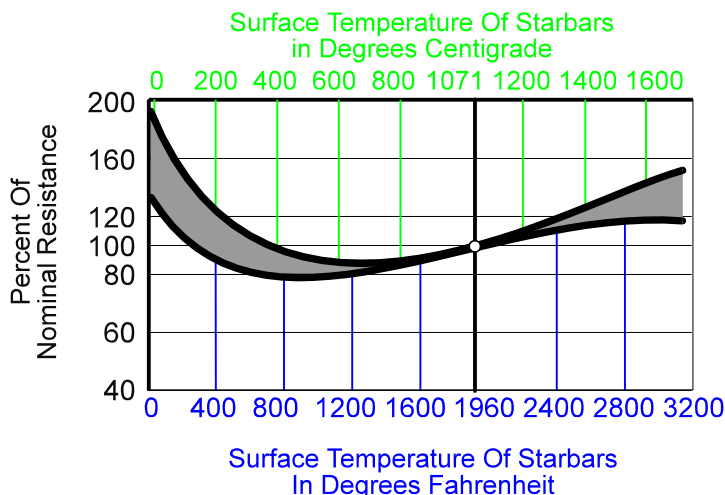

Starbars are test calibrated at a nominal surface temperature of 1960°F (1071°C).

ELECTRICAL CHARACTERISTICS

The silicon carbide Starbar is a linear type resistance heater that converts electrical energy to heat energy -- Joule's Law $W = I^2 \times R$, (W = power in watts, I = current in amperes, R = resistance in ohms).

The SEU STARBAR has a negative resistance temperature characteristic from room temperature to approximately 1200°F (650°). At this temperature it turns positive and remains so throughout its normal operating temperature range. See Typical Resistance Temperature Characteristics Graph, Figure 2, page 2.

Low-Resistant SEU

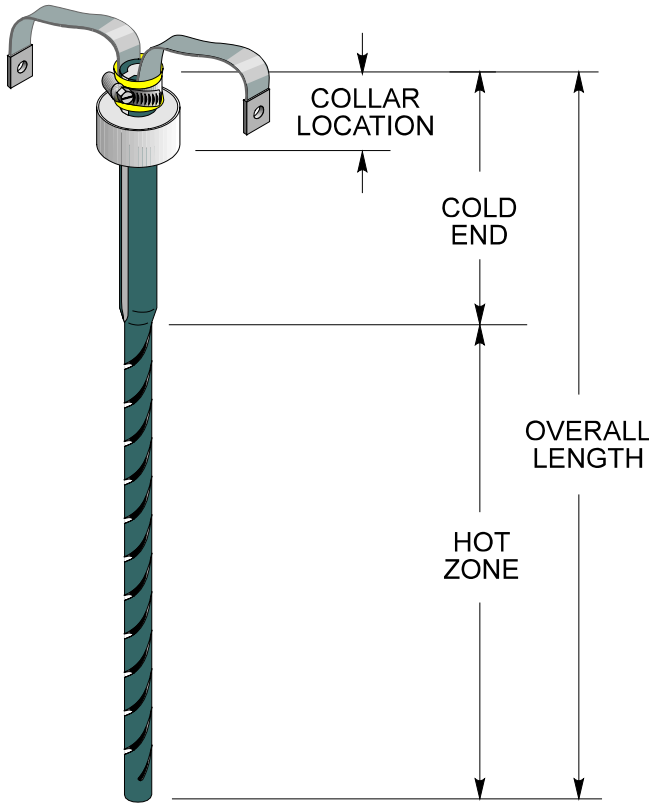

High-Resistant SEU

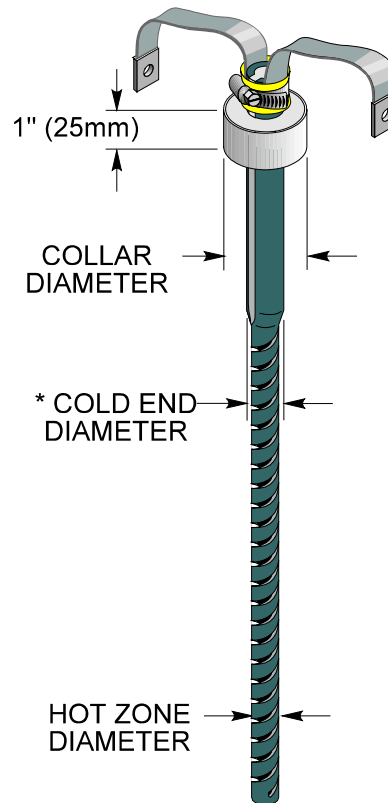

SEU Starbar Dimensions												
Hot Zone Diameter		Cold End Diameter		Collar Diameter		** Collar Location		Strap Rating	Maximum Heating Length		Maximum Overall Length	
MM	Inch	MM	Inch	MM	Inch	MM	Inch	Amps	MM	Inch	MM	Inch
13	1/2	19	3/4	38	1-1/2	50	2	50	254	10	508	20
16	5/8	25	1	57	2-1/4	50	2	50	305	12	610	24
19	3/4	38	1-1/2	57	2-1/4	50	2	50	610	24	914	36
25	1	38	1-1/2	57	2-1/4	76	3	100	813	32	1168	46
32	1-1/4	54	2-1/8	76	3	76	3	100	1016	40	1829	72
38	1-1/2	60	2-3/8	76	3-3/4	76	3	100	1575	62	2311	91
44	1-3/4	67	2-5/8	76	3-3/4	76	3	200	1575	62	2311	91
54	2-1/8	70	2-3/4	76	3-3/4	76	3	200	1575	62	2311	91
70	2-3/4	*70	*2-3/4	95	3-3/4	95	4	400	1575	62	2311	91

* 2-3/4" (70mm) Starbar has equal cold end and hot zone diameters.

** Collar location can be increased from the standards listed.

Strap information: The working length of the SEU strap is 10" (254mm).
The end clip hole diameter for 50 amp braid is 9/32" (7mm), 100 amp braid and over is 9/16" (14mm).

The resistance of the SEU Starbar is dependent on the spiral. The more spiral turns, the higher the resistance.

Nominal Starbar resistance is measured at the calibrating temperature of 1960°F (1070°C). Nominal resistance values of Starbars in ohms per unit of length are shown in Table B, page 5.

ELECTRICAL LOADING

Starbars are not sized to a specific wattage output like metallic heating elements. The amount of energy that a Starbar is capable of converting from electrical to heat energy depends on the ambient furnace temperature and atmosphere in which the Starbar is operating.

When calculating the wattage capabilities of a Starbar, the unit of watts output per unit of radiating surface area is used. Figure 1 shows the recommended watt loading for a square inch or square centimeter of radiating surface as a function of furnace temperature. To determine the recommended wattage capabilities of the Starbars, start with Figure 1. Knowing the furnace temperature and atmosphere in which the Starbars will be operated, follow the temperature line until you intersect the heavy black line (choosing the appropriate line according to the atmosphere in which the Starbar will be operating). Read the loading in watts per square unit of radiating surface that can be applied to the Starbar. To find the total amount of power one Starbar could supply under these conditions, multiply this value by the radiating surface area of the Starbar. The radiating surface area is calculated by multiplying the diameter by the hot zone length by pi (3.14).

Example: At 2750°F, in air, a Starbar could be loaded to 35 watts per square inch. Therefore, a Starbar with 10 square inches of radiating surface could supply 350 watts, whereas a Starbar with 200 square inches of radiating surface could supply 7000 watts.

Metric Calculation: At 1500°C, in air, the Starbar could be loaded to 6 watts per square centimeter. Therefore, a Starbar with 100 square centimeters of radiating surface could supply 600 watts, whereas a Starbar with 2000 square centimeters of radiating surface could supply 12,000 watts.

Example of radiating area:

The SEU 45 x 30 x 1-1/4 has a hot zone length of 30 inches and a diameter of 1.25 inch. The radiating surface area is $30 \times 1.25 \times 3.14$, or 118 square inches.

Metric Calculation: The SEU 1143 x 762 x 32mm has a hot zone length of 762mm and a diameter of 32mm. The radiating surface area is $762 \times 32 \times 3.14$ or 76,566 square millimeters -- converted to centimeters is 766 square centimeters.

POWER SUPPLY

The previous paragraph explained how to calculate the recommended wattage output of the Starbar. The following explains how to compute the electrical requirements to provide the recommended power.

Knowing the wattage output and the resistance of the Starbar you have two parts of an equation with three unknowns. This equation is $E = \sqrt{W \times R}$, (E = nominal full load voltage, W = rating of the Starbar in watts, R = resistance of the Starbar in ohms). The resistance of the Starbar can be calculated using the values found in Table B.

Solving for E determines the voltage required on a nominal-resistance Starbar to provide the wattage output desired. This assumes a nominal resistance.

Example: A Starbar SEU 24 x 16 x 1.25 has a resistance of 5.76 ohms and 63 square inches of radiating surface. Loading to 40 watts per square inch this Starbar could provide 2500 watts. To find the nominal voltage, solve for E.

$$\begin{aligned} E &= \sqrt{W \times R} \\ E &= \sqrt{2500 \times 5.76} \\ E &= 120 \text{ volts} \end{aligned}$$

Starbars may be connected in parallel, series, or combination thereof. Parallel connections are preferred because if the resistance of one or more Starbars increases, its portion of the load will be reduced and the group will remain in balance.

In a parallel arrangement the voltage across all the Starbars is the same. In the formula $W = E^2 \div R$ (W = watts, E = voltage, R = resistance) it can be seen that the greater the resistance, the lower the wattage output. The Starbars in the parallel circuit with the lowest resistance will supply more heat energy and therefore operate at a higher temperature.

This higher Starbar temperature will cause it to gradually increase in resistance until all the Starbars have the same resistance. At this time all the Starbars should have approximately the same resistance values and surface temperatures and therefore remain in balance.

To compute the network resistance of a group of Starbars the following formula may be used:

$R_n = R \times S \div P$ (R_n = network resistance, R = resistance of Starbar, S = number of Starbars connected in a series, P = number of parallel circuits).

Example: Eight Starbars SEU 24 x 16 x 1.25 (R = 5.76 ohms) connected 2 in series (S = 2) and 4 parallel groups (P = 4).

$$R_n = R \times S \div P$$

$$R_n = 5.76 \times 2 \div 4$$

$$R_n = 2.88 \text{ ohms}$$

To compute the nominal network voltage required to power a set of Starbars, a combination of the previous two formulas is used as follows:

$$E_n = \sqrt{W_t \times R_n}, \text{ (} E_n \text{ = nominal network voltage, } R_n \text{ = network resistance, } W_t \text{ = total wattage output).}$$

Example: Eight Starbars SEU 24 x 16 x 1.25 (R = 5.76 ohms) connected 2 in series, 4 parallel groups. Each Starbar provides 2500 watts. $W_t = 8 \times 2500 = 20,000$ watts. $R_n = 2.88$ ohms.

$$E_n = \sqrt{W_t \times R_n}$$

$$E_n = \sqrt{20,000 \times 2.88}$$

$$E_n = 240 \text{ volts}$$

The resistance of Starbars increases gradually during their useful life. Therefore some means of keeping the power input to the kiln or furnace at a level sufficiently high to maintain the desired temperature is required.

Historically, expensive voltage varying equipment such as multiple tap transformers or saturable reactors were recommended for all but the very low temperature applications.

SEU Starbars can be used directly on the line (fixed voltages) at temperatures up to 2500°F (1370°C). To compensate for the reduced output as the Starbars gradually age or increase in resistance, the furnace or kiln is initially overpowered by 25% to 50%.

This type of arrangement eliminates the expensive voltage varying equipment and has proven very satisfactory in many applications. Fixed voltage supply is not recommended when fine process temperature control is required.

Assume a furnace will require approximately 20,000 watts after all heat losses and load factors have been considered. Increasing this 20,000 by 25% to 50% gives a wattage requirement of between 25,000 and 30,000 watts.

By taking another look at the previous examples it can be seen that 10 Starbars SEU 24 x 16 x 1.25 connected two in series, five parallel groups on 240 volts would supply 25,000 watts. If 12 Starbars of the same size Starbars were used, the output would be 30,000 watts.

Twelve Starbars connected four in series, per phase, on 240 volts would make a balanced three phase 240 volt network.

The temperature of the kiln or furnace is controlled by an off-on controller. When the Starbars are new, they will only be powered for 20/25 or 20/30 of the time (the ratio of the power needed to the power available). As the Starbars increase in resistance, they will be on for a greater percentage of the time. When they have increased in resistance to a point at which they supply 30,000 watts, they will be on 100% of the time. A SCR (silicon controlled rectifier) or thyristor can also be used.

Hot Zone Diameter		Hot Zone Resistance Minimum		*Hot Zone Resistance Maximum		Cold End Resistance	
MM	Inch	Ohms / MM	Ohms / Inch	Ohms / MM	Ohms / Inch	Ohms / MM	Ohms / Inch
13	1/2	.00783	.199	.03929	.99784	.00048	.0123
16	5/8	.00492	.125	.03153	.80084	.00027	.0068
19	3/4	.00335	.085	.02362	.60000	.00016	.0042
25	1	.00204	.052	.01969	.50017	.00012	.0030
32	1-1/4	.00126	.032	.01341	.34058	.00007	.0018
38	1-1/2	.00083	.021	.01103	.28022	.00005	.0013
44	1-3/4	.00070	.018	.00960	.24391	.00004	.0011
54	2-1/8	.00059	.015	.00636	.16159	.00004	.0012
70	2-3/4	.00039	.010	.00379	.09622	.00004	.0010

Note: All Resistance values are +/- 20%.
* The maximum hot zone resistance is limited by the hot zone length.

For applications where close temperature control is desired and/or for temperatures above 2500°F (1370°C), a device for increasing the voltage to the Starbars is required. There are several methods of providing this variable voltage source.

(1) Multiple tap transformers are the most common because it is usually the least expensive. The secondary of the transformer is provided with taps that usually vary in number from 10 to 36. By carefully selecting the voltage taps, the correct voltage output to match the resistance of the Starbars over their complete useful life can be made.

(2) Saturable reactors and induction regulators are used to provide a stepless voltage control. They are also sometimes used with multiple tap transformers.

(3) Capacitor controls are used infrequently. They, of course, will tend to improve a power factor that makes their use desirable in some areas.

(4) Silicon controlled rectifiers (SCR) have become quite popular with the advances in solid state devices.

To compensate for the reduced output as the Starbars increase in resistance, a voltage range is required that will compensate for a 100% increase in the Starbar resistance. The following formula may be used to figure Emax: $E_{max} = \sqrt{(Wt \times R_n) \times 1.5}$, (Emax = recommended maximum voltage required to compensate for increase in resistance due to aging and resistance tolerance, Wt = rating of transformer in watts, Rn = network resistance of the Starbars, 1.5 = minimum margin to accommodate the doubling of the Starbar network resistance and the plus 20% resistance tolerance). A higher value will offer slightly longer usable service life.

Example: A transformer is rated at 24 KVA and has a computed nominal full load voltage of 240 volts. (Rn = 2.88, Wt = 20,000 for 8 Starbars)

$$\begin{aligned} E_{max} &= \sqrt{(Wt \times R_n) \times 1.5} \\ E_{max} &= \sqrt{(20,000 \times 2.88) \times 1.5} \\ E_{max} &= \sqrt{(57,600) \times 1.5} \\ E_{max} &= 360 \text{ volts} \end{aligned}$$

The nominal full load voltage and maximum voltage have been computed.

When specifying the transformer, the nominal full load voltage is usually reduced to allow for the minus 20% resistance tolerance of the Starbars and slow furnace heatup.

To calculate the minimum voltage, take 70% of the nominal voltage. For periodic applications, take 30% of the nominal full load voltage.

Auto transformers may be used if primary voltage is 230 volts or less. They should not be used in a three phase arrangement. Accepted practice limits the secondary voltage on all transformers to 300 volts. Above this, refractory voltage leakage becomes a problem.

When computing the size of the voltage steps between taps, a value of 5% of the nominal full load voltage is often used. When SCR or thyristor controls are used on the primary, fewer taps are required. For example, if 6 taps are used, the idling tap can be 0.7 x nominal voltage, then each consecutive tap would be 14% higher. For 8 taps, the idling tap would again be 0.7 x nominal voltage, each consecutive tap at 9.1% higher than the preceding.

CUSTOM ELECTRICAL RESISTANCE

The SEU can be manufactured with a range of electrical resistances. The lowest resistance is accomplished by no spiral -- a straight cut in the hot zone. The high resistance can match the resistance of the SER Starbar. The low resistance is close to the RR Starbar. The minimum and maximum resistance values are shown on Table B, page 5.

EASE OF REPLACEMENT

SEU Starbars can be replaced while the furnace is at operating temperature. The power to the Starbars being changed should be shut off. The aluminum braids can then be disconnected from the buss and the old elements removed. The new Starbar should be inserted smoothly through the hot furnace with sufficient speed to insure that the aluminum is not melted off the terminal end but not so fast as to cause thermal shock.

ELEMENT SPACING

Starbars should not be placed closer than two Starbar diameters to each other or one and one half Starbar diameters to a wall or other reflecting body. If the Starbar is not able to dissipate heat energy equally in all directions, it may cause local overheating and possible failure. The formula for computing the recommended Starbar spacing to obtain an even temperature gradient on the product being heated is shown in Figure 3.

SERVICE LIFE

Starbars increase gradually in resistance with use. This characteristic of increasing in resistance is called aging. Aging is a function of the following:

1. Operating temperature
2. Electrical loading - usually expressed in watts per square inch or watts per square centimeter of Starbar radiating surface
3. Atmosphere
4. Type of operation (continuous or intermittent)
5. Operating and maintenance techniques

MOUNTING

SEU Starbars can be mounted vertically or horizontally. When mounted horizontally, the hot end does not need to be supported, however, make sure that the slot in the terminal end is not in contact with the insulation in the wall of the furnace or kiln. This is most easily accomplished by placing the slot in a horizontal position.

The terminal holes should be 10% larger than the diameter of the element. Extreme caution should be used when mounting to ensure that the Starbars are not placed in tension. There should be adequate freedom to allow the furnace and Starbars to expand and contract independently.

Starbars should have their heating sections centered in the furnace chamber so that no portion of the heating section extends into the furnace wall. A conical or truncated cone shaped recess 1/2 inch (13mm) deep is sometimes located on the interior wall where the Starbar passes through. This allows the hot zone to radiate properly and helps maintain a uniform temperature in the kiln.

FURNACE HEATING CHAMBER

The furnace heated chamber dimension, which the Starbar spans, can be the same as the Starbar hot zone as shown in Figure 3 below). Recommended terminal hole diameters for various refractory walls can be calculated by increasing the Starbar outer diameter by 10%. As an example, a 1.25" diameter SEU Starbar would require a 1.38" terminal hole ($1.25 \times 1.10 = 1.38$). In metric, a 32mm diameter SEU Starbar would require a 35mm terminal hole ($32\text{mm} \times 1.10 = 35\text{mm}$).

RECOMMENDED SEU STARBAR SPACING

- X = 2 x Starbar hot zone diameter is the minimum, 1.5 x Starbar hot zone diameter is the absolute minimum and requires a reduced Starbar surface watt loading
- Z = $S \div 1.73$ minimum for moving loads
- S = 2 x Starbar hot zone diameter minimum
- X - distance from the centerline of Starbar to any reflecting surface, such as a refractory wall or product
- Z - distance from the centerline of the Starbar to a moving or stationary load
- S - distance from centerline of one Starbar to the centerline of an adjacent Starbar

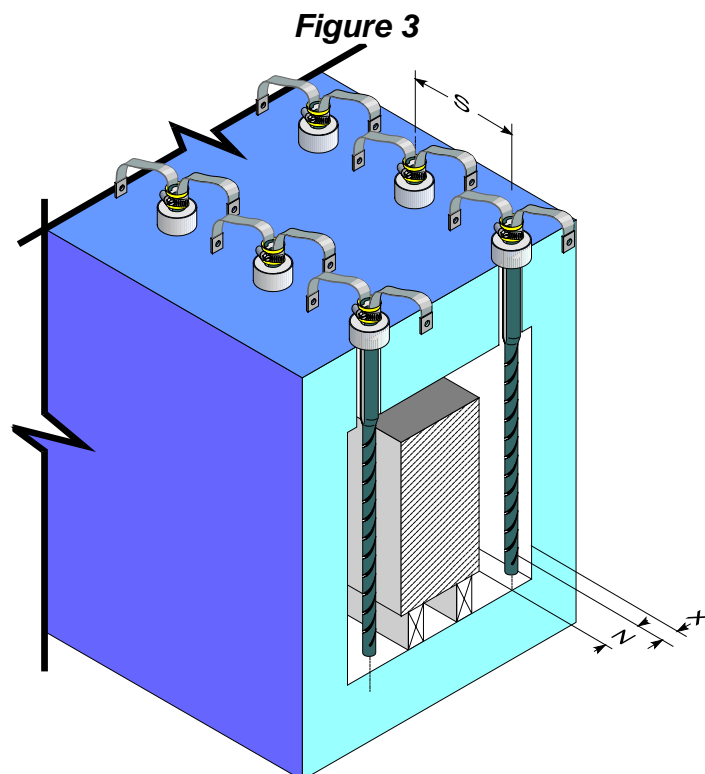

SPECIFICATIONS AND MATCHING

Starbars have a manufactured tolerance of plus or minus 20% on the nominal resistance. All Starbars are calibrated at least twice prior to shipping to ensure their being within specifications. The calibrated amperage of each Starbar is marked on the carton and collar end of each Starbar. When installing, arrange Starbars with amperage values as close to each other as available. Longer service life will be obtained when series connected Starbars are matched in resistance. Starbars are shipped as closely matched as possible.

SEU IN PROTECTION TUBE

We recommend a 25mm (1") annular space around the hot zone when placed inside a protection tube.

AVAILABILITY

Starbars can be shipped from stock, or two to three weeks after receipt of an order.

SEU within a Protection Tube, with a Lead-in Sleeve

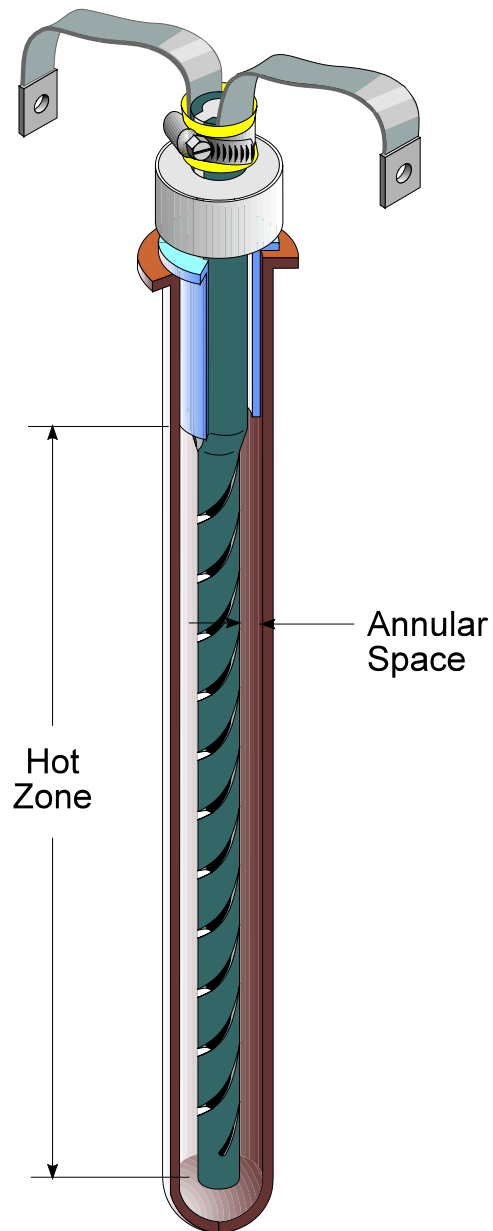

I SQUARED R ELEMENT CO., INC.

PO Box 390, 12600 CLARENCE CENTER ROAD, AKRON, NEW YORK, USA 14001-0390
www.isquaredrelement.com; email: sales@isquaredrelement.com

PHONE (01) 716 542-5511 FAX (01) 716 542-2100