

TYPE SE and TSE, SILICON CARBIDE SPIRAL HEATING ELEMENTS

GENERAL DESCRIPTION

The spiral Starbars are made of special high-density reaction-bonded silicon carbide. A spiral slot in the hot zone reduces the cross sectional area. This provides the electrical resistance ratio to make the ends cool and the hot zone hot. Special cold ends may be welded to further enhance the resistance ratio. To provide a low resistance contact surface the extremities are metallized with aluminum. The electrical connections are made with flat aluminum braids and spring clamps. The terminal ends of the SE element are normally plugged.

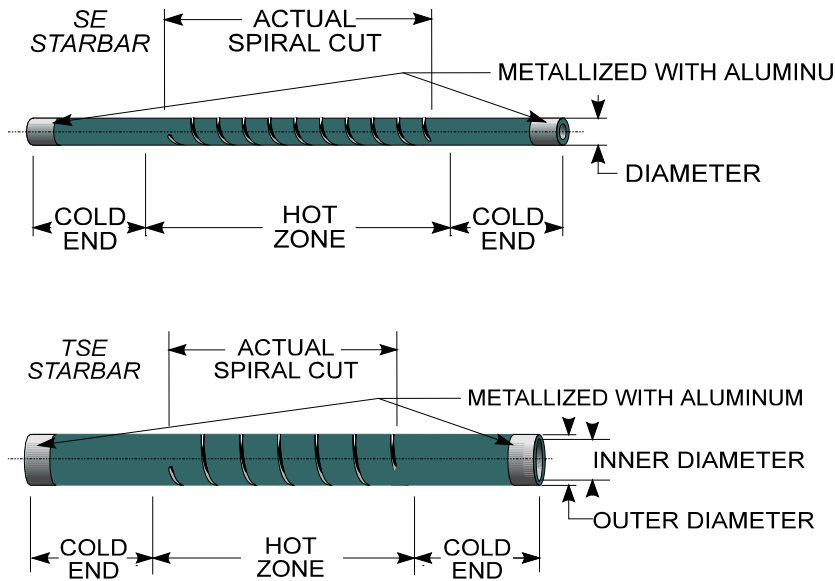

SE and TSE Starbars are described by giving the overall length, the heating section length, and the diameter. As an example, SE 36x14x1 is a spiral element 36" long with a 14" hot zone and 1" in diameter. In millimeters, a SE 914x356x25 is a spiral element 914 mm long with a 356 mm hot zone and 25 mm in diameter. A TSE 36x14x3 is a tube-type spiral element 36" long with a 14" hot zone, and a 3" outer diameter. In millimeters, a TSE 914x356x75 is a tube-type spiral element 914 mm long with a 356 mm hot zone and 75mm outer diameter.

TSE Starbars are available in five different diameters. The TSE is similar to the SE. The TSE Starbar has a thin wall construction and an internal diameter open from end to end. The thin wall construction makes this Starbar useful for tube furnace applications.

SUPERIOR PERFORMANCE

At 2.7 gms/cc this high-density low-porosity element is able to survive severe environments. The high density prevents the internal lattice structure from being oxidized. This Starbar has an extremely slow aging characteristic.



Silicon Carbide Heating Elements



I SQUARED R ELEMENT CO., INC.

Recommended Maximum Watt Loading (Figure 1)

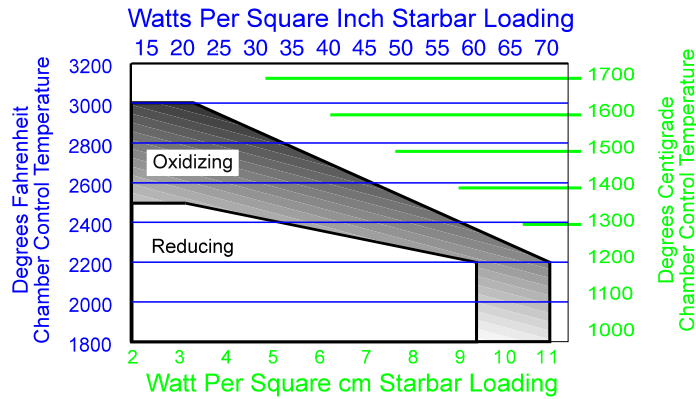

INTERCHANGEABILITY

Starbars are interchangeable with all spiral silicon carbide heating elements manufactured in the United States as well as higher resistance heating elements manufactured for the Asian and European markets. It is important to provide the nominal electrical resistance when ordering Starbars.

SIZES AVAILABLE

SE Starbars can be manufactured up to 93 inches (2362mm) long. The maximum hot zone length is 60 inches (1524mm) at this printing. Please see Table A, page 3, for diameters and lengths available.

OPERATING TEMPERATURES

In an air or inert atmosphere of argon or helium the SE and TSE Starbars can be operated at furnace temperatures up to 3000°F (1650°C). In reducing atmospheres the maximum operating temperature is 2500°F (1371°C). See Watt Loading Graph, Figure 1.

There is a protective coating of silicon dioxide on the silicon carbide. Hydrogen reduces this coating and causes the Starbar to deteriorate. Very dry or very wet hydrogen is detrimental to long service life. Nitrogen atmosphere applications are limited to 2500°F (1370°C) and a maximum watt loading of 20 to 30 watts per square inch (3.1 to 4.6 watts per square centimeter). Too high of a surface temperature will result in silicon nitride formation. A thermally insulative layer forms around the Starbar resulting in very high surface temperatures which damage the Starbars.

ELECTRICAL CHARACTERISTICS

The silicon carbide Starbar is a linear type resistance heater that converts electrical energy to heat energy -- Joule's Law $W = I^2 \times R$, (W = power in watts, I = current in amperes, R = resistance in ohms).

Resistance Temperature Characteristics (Figure 2)

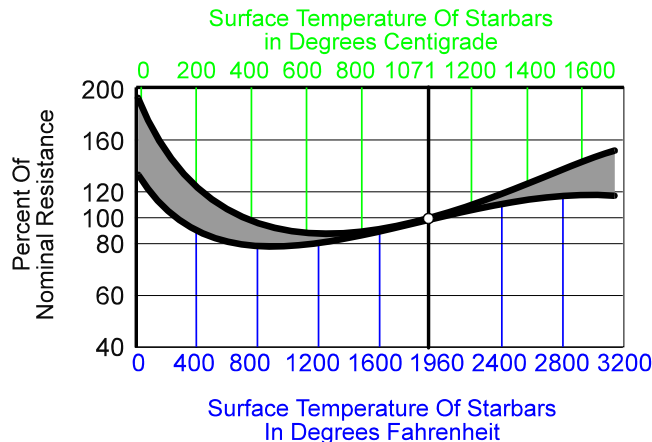

Starbars are test calibrated at a nominal surface temperature of 1960°F (1071°C).

The spiral Starbars are a reaction bonded silicon carbide. They have a negative resistance temperature characteristic from room temperature to approximately 1200°F (650°C). At this temperature it turns positive and remains so throughout its normal operating temperature range. See Typical Resistance/Temperature Characteristics Graph, Figure 2.

Nominal Starbar resistance is measured at the calibrating temperature of 1960°F (1071°C). Nominal resistance values of Starbars in ohms per unit length are shown in Table B, page 4.

ELECTRICAL LOADING

Starbars are not sized to a specific wattage output like metallic heating elements. The amount of energy that a Starbar is capable of converting from electrical to heat energy depends on the ambient furnace temperature and atmosphere in which the Starbar is operating.

When calculating the wattage capabilities of a Starbar, the unit of watts output per unit of radiating surface area is used. Figure 1, page 2, shows the recommended watt loading for a square inch or square centimeter of radiating surface area as a function of furnace temperature. To determine the recommended wattage capabilities of the Starbars, start with Figure 1. Knowing the furnace temperature and atmosphere in which the Starbars will be operated, follow the temperature line until you intersect the heavy black line (choosing the appropriate line according to the atmosphere in which the Starbar will be operating). Read the loading in watts per square unit of radiating surface area that can be applied to the Starbar. To find the total amount of power one Starbar could supply under these conditions, multiply this value by the radiating surface area of the Starbar. The radiating surface area is calculated by multiplying the diameter by the hot zone length by pi (3.14).

Table A									
SE Starbar Dimensions									
Diameter		* Maximum Heating Length		* Maximum Overall Length		** Maximum Load Tube OD		Starbar ID	
MM	Inch	MM	Inch	MM	Inch	MM	Inch	MM	Inch
10	3/8	250	10	762	30	3	1/8	5	3/16
13	1/2	305	12	787	32	3	1/8	5	3/16
16	5/8	355	14	864	34	6	1/4	8	5/16
19	3/4	555	22	1067	42	8	5/16	9.5	3/8
22	7/8	660	26	1270	50	9	3/8	12.5	1/2
25	1	760	30	1549	61	13	1/2	14	9/16
32	1-1/4	1015	40	1803	71	14	9/16	17	11/16
35	1-3/8	1015	40	1803	71	17	11/16	21	13/16
38	1-1/2	1015	40	1803	71	21	13/16	24	15/16
45	1-3/4	1220	48	2007	79	24	15/16	27	1-1/16
54	2-1/8	1320	52	2159	85	30	1-3/16	33	1-5/16
70	2-3/4	1525	60	2362	93	46	1-13/16	49	1-15/16
TSE Starbar Dimensions									
45	1-3/4	610	24	991	39	29	1.14	37	1.46
50	2	610	24	991	39	32	1.25	40	1.57
55	2-1/8	610	24	991	39	36	1.41	44	1.73
62	2-1/2	610	24	991	39	46	1.81	54	2.12
75	3	610	24	991	39	59	2.32	67	2.63
*Recommended Maximum Lengths = 70% of Maximum Lengths.									
**Recommended maximum load tube OD is based on short heating sections and overall lengths. Due to different thermal expansion rates, ovalness, and lack of straightness of both the Starbar and load tubes, further reductions may be needed.									

Example of radiating area: The SE 36x14x1 has a hot zone length of 14 inches and a diameter of 1 inch. The radiating surface area is 14 x 1 x 3.14, or 44 square inches. The SE 914x356x25mm has a hot zone length of 356mm and a diameter of 25mm. The radiating surface area is 356x25x3.14 or 27,946 square millimeters -- converted to centimeters is 279 square centimeters.

Example of power: At 2750°F, in air, a Starbar could be loaded to 35 watts per square inch. Therefore, a Starbar with 10 square inches of radiating surface could supply 350 watts, whereas a Starbar with 200 square inches of radiating surface could supply 7000 watts. At 1500°C, in air, the Starbar could be loaded to 6 watts per square centimeter. Therefore, a Starbar with 100 square centimeters of radiating surface could supply 600 watts, whereas a Starbar with 2000 square centimeters of radiating surface could supply 12,000 watts.

POWER SUPPLY

The previous paragraph explained how to calculate the recommended wattage output of the Starbar. The following explains how to compute the electrical requirements to provide the recommended power.

Knowing the wattage output and the resistance of the Starbar you have two parts of an equation with three unknowns. This equation is $E = \sqrt{(W \times R)}$, (E = nominal full load voltage, W = rating of the Starbar in watts, R = resistance of the Starbar in ohms). The resistance of the Starbar can be calculated using the values found in Table B.

Solving for E determines the voltage required on a nominal resistance Starbar to provide the wattage output desired. This assumes a nominal resistance.

Example: A Starbar SE 36 x 14 x 1 has a resistance of 1.83 ohms and 44 square inches of radiating surface. Loading to 45 watts per square inch, this Starbar could provide 2000 watts. To find the nominal voltage solve for E.

$$E = \sqrt{(W \times R)}$$

$$E = \sqrt{(2000 \times 1.80)}$$

$$E = 60 \text{ volts}$$

Starbars may be connected in parallel, series, or combination thereof. Parallel connections are preferred, for if the resistance of one or more Starbars increases, its portion of the load will be reduced and the group will remain in balance.

In a parallel arrangement the voltage across all the Starbars is the same. In the formula $W = E^2 \div R$ (W = watts, E = voltage, R = resistance) it can be seen that, the greater the resistance, the lower the wattage output. The Starbars in the parallel circuit with the lowest resistance will supply more heat energy and therefore operate at a higher temperature.

This higher Starbar temperature will cause it to gradually increase in resistance until all the Starbars have the same resistance. At this time all the Starbars should have approximately the same resistance values and surface temperatures and therefore remain in balance.

To compute the network resistance of a group of Starbars the following formula may be used:
 $R_n = R \times S \div P$ (R_n = network resistance, R = resistance of Starbar, S = number of Starbars connected in a series, P = number of parallel circuits).

Example: Eight Starbars SE 36 x 14 x 1 (R = 1.83 ohms) connected 2 in series (S = 2) and 4 parallel groups (P = 4).

Table B					
*SE Electrical Resistance					
Diameter		**Hot Zone Resistance		Cold End Resistance	
MM	Inch	Ohms / MM	Ohms / Inch	Ohms / MM	Ohms / Inch
10	3/8	.01940	.49300	.00173	.04400
13	1/2	.00909	.23093	.00192	.04876
16	5/8	.00698	.17729	.00129	.03288
19	3/4	.00559	.14208	.00097	.02464
22	7/8	.00507	.12885	.00077	.01968
25	1	.00455	.11561	.00058	.01471
32	1-1/4	.00314	.07968	.00038	.00976
35	1-3/8	.00223	.05669	.00022	.00567
38	1-1/2	.00214	.05430	.00025	.00645
45	1-3/4	.00182	.04624	.00022	.00554
54	2-1/8	.00135	.03418	.00016	.00417
70	2-3/4	.00094	.02378	.00011	.00272
*TSE Electrical Resistance					
45	1-3/4	.00672	.17062	.00034	.00875
50	2	.00672	.17062	.00034	.00875
55	2-1/8	.00672	.17062	.00034	.00875
62	2-1/2	.00672	.17062	.00034	.00875
75	3	.00672	.17062	.00034	.00875

* All Resistance values are +/- 20%.
 ** The spiraled hot zone (hot zone -1") is used to calculate the hot zone resistance.

$$R_n = R \times S \div P$$

$$R_n = 1.80 \times 2 \div 4$$

$$R_n = 0.90 \text{ ohms}$$

To compute the nominal network voltage required to power a set of Starbars, a combination of the previous two formulas is used as follows:

$$E_n = \sqrt{W_t \times R_n}, \text{ (} E_n = \text{nominal network voltage, } R_n = \text{network resistance, } W_t = \text{total wattage output).}$$

Example: Eight Starbars SE 36 x 14 x 1 (R = 1.80 ohms) connected 2 in series, 4 parallel groups. Each Starbar provides 2000 watts. $W_t = 8 \times 2000 = 16,000$ watts. $R_n = 0.90$ ohms.

$$E_n = \sqrt{W_t \times R_n}$$

$$E_n = \sqrt{16,000 \times 0.90}$$

$$E_n = 120 \text{ volts}$$

The resistance of Starbars increases gradually during their useful life. Therefore, some means of keeping the power input to the kiln or furnace at a level sufficiently high to maintain the desired temperature is required.

Historically, expensive voltage varying equipment such as multiple tap transformers or saturable reactors were recommended for all but the very low temperature applications.

Spiral Starbars can be used directly on the line (fixed voltages) at temperatures up to 2500°F (1370°C). To compensate for the reduced output as the Starbars gradually age or increase in resistance, the furnace or kiln is initially overpowered by 25% to 50%. This type of arrangement eliminates the expensive voltage varying equipment and has proven very satisfactory in many applications. It is not recommended when fine process temperature control is required.

Assume a furnace will require approximately 16,000 watts after all heat losses and load factors have been considered. Increasing this 16,000 by 25% to 50% gives a wattage requirement of between 20,000 and 24,000 watts.

By taking another look at the previous examples it can be seen that 10 Starbars SE 36 x 14 x 1 connected two in series, five parallel groups on 120 volts would supply the 20,000 watts. If 12 Starbars, two in series, six parallel groups, of the same size were used the output would be 24,000 watts.

Twelve Starbars connected four in series, per phase, on 240 volts would make a balanced three phase 240 volt network.

The temperature of the kiln or furnace is controlled by an off-on controller. When the Starbars are new, they will only be powered for 16/20 or 16/24 of the time (the ratio of the power needed to the power available). As the Starbars increase in resistance they will be on for a greater percentage of the time. When they have increased in resistance to a point at which they supply 16,000 watts, they will be on 100% of the time. A SCR (silicon controlled rectifier) or thyristor can also be used.

For applications where close temperature control is desired and/or for temperatures above 2500°F (1370°C), a device for increasing the voltage to the Starbars is required. There are several methods of providing this variable voltage source.

1. The multiple tap transformer is the most common because it is usually the least expensive. The secondary of the transformer is provided with taps which usually vary in number from 10 to 36. By carefully selecting the voltage taps, the correct voltage output to match the resistance of the Starbars over their complete useful life can be made.
2. Saturable reactors and induction regulators are used to provide a stepless voltage control. They are also sometimes used with multiple tap transformers.
3. Capacitor controls are used infrequently. They, of course, will tend to improve a power factor which makes their use desirable in some areas.
4. Silicon controlled rectifiers (SCR) have become quite popular with the advances in solid state devices.

To compensate for the reduced output as the Starbars increase in resistance, a voltage range is required that will compensate for a 100% increase in the Starbar resistance. The following formula may be used to calculate E_{max} : $E_{max} = \sqrt{W_t \times R_n} \times 1.5$, (E_{max} = recommended maximum voltage required to compensate for increase in resistance due to aging and resistance tolerance, W_t = rating of transformer in watts, R_n = network resistance of the Starbars, 1.5 = minimum margin to accommodate the doubling of the Starbar network resistance and the plus 20% resistance tolerance). A higher value will offer slightly longer usable service life.

Example: A transformer is rated at 16 KVA and has a computed nominal full load voltage of 120 volt ($R_n = .90$, $W_t = 16,000$ for 8 Starbars).

$$E_{max} = \sqrt{(Wt \times R_n)} \times 1.5$$
$$E_{max} = \sqrt{(16,000 \times .90)} \times 1.5$$
$$E_{max} = \sqrt{14,400} \times 1.5$$
$$E_{max} = 180 \text{ volts}$$

The nominal full load voltage and maximum voltage have been computed.

When specifying the transformer, the nominal full load voltage is usually reduced to allow for the minus 20% resistance tolerance of the Starbars and slow furnace heatup.

To calculate the minimum voltage, take 70% of the nominal voltage. For periodic applications, take 30% of the nominal full load voltage.

Auto transformers may be used if primary voltage is 230 volts or less. They should not be used in a three phase arrangement. Accepted practice limits the secondary voltage on all transformers to 300 volts. Above this refractory voltage leakage becomes a problem.

When computing the size of the voltage steps between taps, a value of 5% of the nominal full load voltage is often used. When SCR or thyristor controls are used on the primary, fewer taps are required. For example, if 6 taps are used, the idling tap can be 0.7 x nominal voltage, then each consecutive tap would be 14% higher. For 8 taps, the idling tap would again be 0.7 x nominal voltage, each consecutive tap at 9.1% higher than the preceding.

EASE OF REPLACEMENT

SE and TSE Starbars can be replaced while the furnace is at operating temperature. The power to the Starbars being changed should be shut off, the spring clips and aluminum braid released, and the old Starbar removed. The new Starbar should be inserted smoothly through the hot furnace with sufficient speed to insure that the aluminum is not melted off the terminal end but not so fast as to cause thermal shock.

SERVICE LIFE

Starbars gradually increase in resistance with use. This characteristic of increasing in resistance is called aging. Aging is a function of the following:

- (1) Operating temperature
- (2) Electrical loading - usually expressed in watts per square inch or watts per square centimeter of Starbar radiating surface
- (3) Atmosphere
- (4) Type of operation (continuous or intermittent)
- (5) Operating and maintenance techniques

MOUNTING

There are no restrictions on the mounting positions of Starbars, although the horizontal and vertical positions are the more common. Extreme caution should be used when mounting to ensure that the Starbars are not placed in tension. There should be adequate freedom to allow for the furnace and Starbars to expand and contract independently.

When mounting Starbars vertically, they must be supported on the lower end by electrically insulated supports. Starbars should have their heating sections centered in the furnace chamber so that no portion of the heating section extends into the furnace wall. A conical or truncated cone shaped recess 1/2 inch (13mm) deep is sometimes located on each interior wall where the Starbar passes through. This allows the hot zone to radiate properly and helps maintain a uniform temperature in the kiln.

FURNACE HEATING CHAMBER

The furnace heated chamber dimension, which the Starbar spans, can be the same as the Starbar hot zone (as shown in Figure 3, page 8). Alternately, the furnace heating chamber dimension, which the Starbar spans, can be one inch (25mm) less than the effective heating length of the Starbar. In this case there must be a 45° conical recess in the furnace wall, as shown in Figure 3, for the Starbars above the load. Recommended terminal hole diameters for various refractory walls and Starbar sizes are shown in Table C, page 7.

PECIFICATIONS AND MATCHING

Starbars have a manufactured tolerance of plus or minus 20% on the nominal resistance. All Starbars are calibrated at least twice prior to shipping to ensure their being within specifications. The calibrated amperage of each Starbar is marked on the carton and right hand end of each Starbar. When installing, arrange Starbars with amperage values as close to each other as available. Longer service life will be obtained when series connected Starbars are matched in resistance. Starbars are shipped as closely matched as possible.

STARBAR SPACING

Starbars should not be placed closer than two Starbar diameters to each other or one and one half Starbar diameters to a wall or other reflecting body (from the center line of the Starbar). If the Starbar is not able to dissipate heat energy equally in all directions, it may cause local overheating and possible failure. The formula for computing the recommended Starbar spacing to obtain an even temperature gradient on the product being heated is shown in Figure 3, page 8.

AVAILABILITY

Starbars can be shipped from stock, or two to three weeks after receipt of an order.

CUSTOM CONFIGURATIONS

The ID of the SE cold ends is normally plugged. The SE is alternatively available with a clear ID which allows it to be used as a tube heater. The SE should be used as a tube heater rather than the TSE because the wall is thicker making it stronger. The TSE should be used only when the ID of the SE is not large enough.

Special higher custom resistance values are available. This is accomplished by machining a smaller spiral width, therefore very high resistance and/or long hot zone lengths are not practical. Lower than standard resistances are not recommended.

ELECTRICAL CONNECTORS

Held in place by clamps, braided aluminum terminal straps in 25, 50, 100, and 200 ampere ratings, are available in three styles: Single Loop (for connecting binding post to element) and Double Loop (for connecting element to element) and Post to Post. Detailed descriptions and part numbers can be found in our Starbar accessory literature.

TERMINAL CLAMPS

There are two type of clamps: Type "M", manual, (derives its name from its similarity to the letter M) and Type "T", used with a tool. Please refer to our accessory literature for a detailed part number and description.

Table C
Recommended Minimum Refractory Hole Size

Starbar Diameter		Minimum Hole Diameter Based on Refractory Wall Thickness									
		100	150	200	300	400	3	5	6.5	9	13.5
MM	Inch	MM	MM	MM	MM	MM	Inch	Inch	Inch	Inch	Inch
10	3/8	15	15	16	--	--	9/16	9/16	5/8	--	--
11	7/16	16	17	18	20	--	5/8	11/16	11/16	3/4	--
13	1/2	18	19	20	22	--	11/16	3/4	3/4	13/16	--
16	5/8	21	22	23	25	--	13/16	7/8	7/8	15/16	--
19	3/4	25	25	26	28	--	15/16	1	1	1-1/16	--
25	1	31	32	33	35	37	1-3/16	1-1/4	1-1/4	1-5/16	1-7/16
32	1-1/4	38	39	40	42	44	1-1/2	1-1/2	1-9/16	1-9/16	1-11/16
35	1-3/8	41	42	43	45	47	1-5/8	1-5/8	1-11/16	1-11/16	1-13/16
38	1-1/2	45	45	46	48	50	1-3/4	1-3/4	1-13/16	1-7/8	1-15/16
45	1-3/4	51	52	53	55	57	2	2-1/16	2-1/16	2-1/8	2-3/16
54	2-1/8	61	62	63	65	67	2-3/8	2-7/16	2-7/16	2-1/2	2-9/16
63	2-1/2	71	72	73	75	77	2-13/16	2-13/16	2-7/8	2-7/8	3
70	2-3/4	78	79	80	82	84	3-1/16	3-1/16	3-1/8	3-3/16	3-1/4
76	3	85	85	86	88	90	3-5/16	3-3/8	3-3/8	3-7/16	3-1/2

RECOMMENDED SE STARBAR SPACING

X - Distance from the centerline of Starbar to any reflecting surface, such as a refractory wall or product.

Z - Distance from the centerline of the Starbar to a moving or stationary load.

S - Distance from centerline of the Starbar to the centerline of an adjacent Starbar.

X = 2 x Starbar diameter is the minimum,
1.5 x Starbar diameter is the absolute minimum
and requires a reduced Starbar surface watt
loading.

Z = S ÷ 1.41 minimum for stationary loads

Z = S ÷ 1.73 minimum for moving loads.

S = 2 x Starbar diameters minimum.

Figure 3

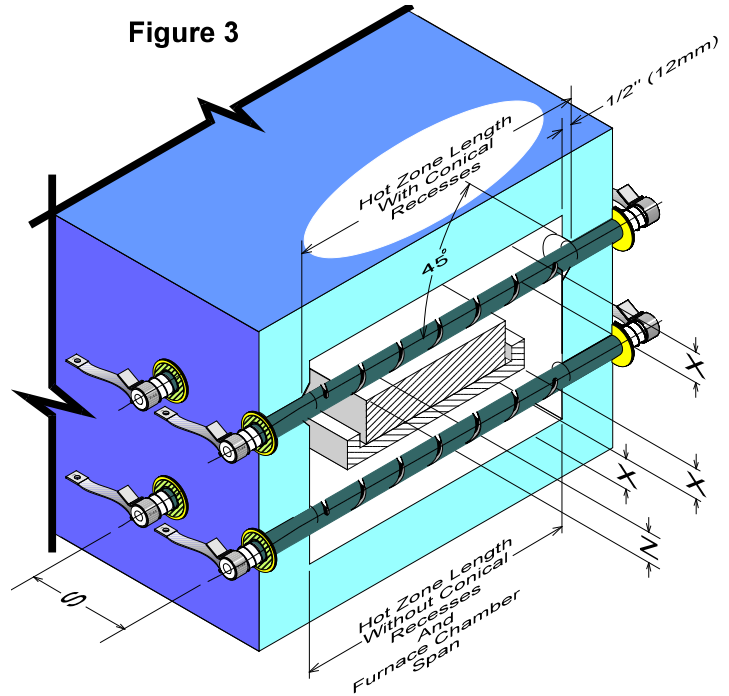

TSE IN FURNACE

Refer to Table A for maximum load tube diameters

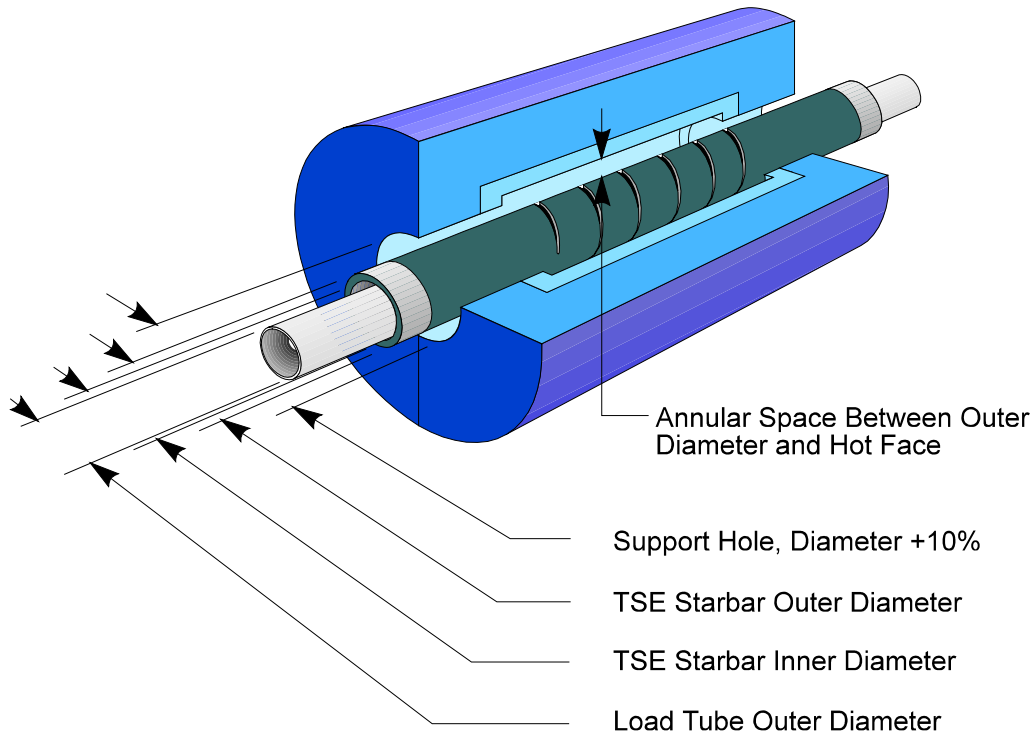

I SQUARED R ELEMENT CO., INC.

PO Box 390, 12600 CLARENCE CENTER ROAD, AKRON, NEW YORK, USA 14001-0390

PHONE (01) 716 542 5511